

AMERICAN RANGE

QUALITY PROFESSIONAL COOKING EQUIPMENT

48" ICONICA RANGES (DUAL FUEL)

PERFORMER OPEN BURNERS



RANGE TOP FEATURES

- True commercial lift-off burners for easy cleaning.
- Three sizes of burners to serve your everyday needs:
25,000 BTU (lg), 18,000 BTU (med), 12,000 BTU (sm)
- Variable flame settings for all Performer open burners.
- Automatic, electronic re-ignition.
- Continuous cast iron grates allow for easy transfer of pots and pans across the entire cooking surface.
- Porcelainized burner pans catch spills and lift out for easy cleaning.
- Dual action valves provide easy, safe operation.
- **Stainless steel Island Back trim included and installed.**



OVEN FEATURES

30" Convection Oven (5.0 c.f.)

Bake element 3,500 watts
Broil element 3,500 watts
Convection element 2,500 watts

18" Convection Oven (2.7 c.f.)

Bake element 2,400 watts
Broil element 2,400 watts
Convection element 2,500 watts
Modes: Bake, Convection Bake, Broil, Fan, Roast, Convection Roast, Warm, Proof, Dehydrate, Clean

- Red lights indicate oven functions.
- The Advanced Cooking System creates uniform air flow by cycling different elements depending on cooking mode.
- Two chrome plated, heavy-duty racks with six positions on heavy gauge chrome side supports.
- Eight-pass broiler provides rapid searing with 3,500 watts of power.
- Large oven accommodates full size commercial sheet pans.
- Oven lights controlled by switch on front panel. Oven front construction is a durable, precision-made one piece frame.



ARROB-486GRDF
Shown with optional leg caps.



ARROB-488DF

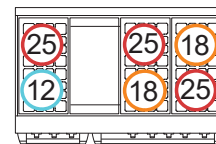

ARROB-486GDDF

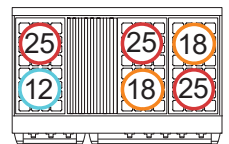

ARROB-486GRDF

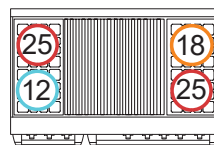

ARROB-4842GRDF

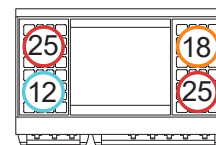

ARROB-4842GDDF

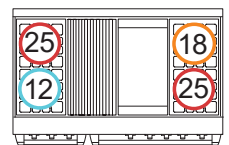

ARROB-484GDGRDF

BURNER CONFIGURATIONS

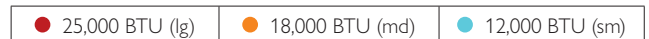

CONVECTION OVEN TECHNOLOGY



Balanced heat distribution is essential when baking, roasting, and dehydrating food. The American Range convection oven technology features a convection motor and louvered side panels to enhance uniform heat distribution throughout the large oven cavity. The strategic placement of the convection fan ensures consistent heat distribution.

CONVECTION OVENS ARE GREEN TECHNOLOGY

The highly efficient design of the Convection Oven uses less gas versus a standard oven.

CUSTOMIZE YOUR RANGE

Pick any RAL color to match the color that best suits your lifestyle.



See ralcolorchart.com for color options for the front panel and toe kick. Knobs cannot be customized.



www.AmericanRangeHome.com



48" PERFORMER ICONICA RANGES – DUAL FUEL

OPEN BURNERS/ELECTRIC OVENS

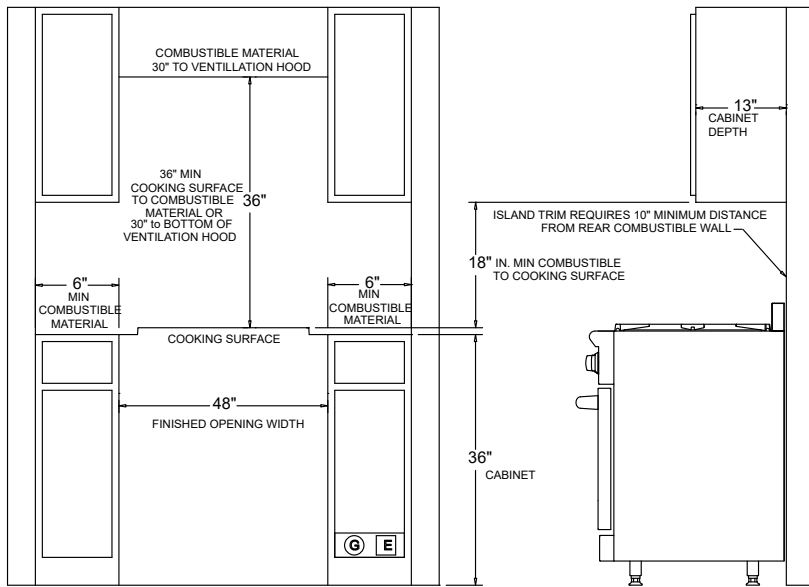
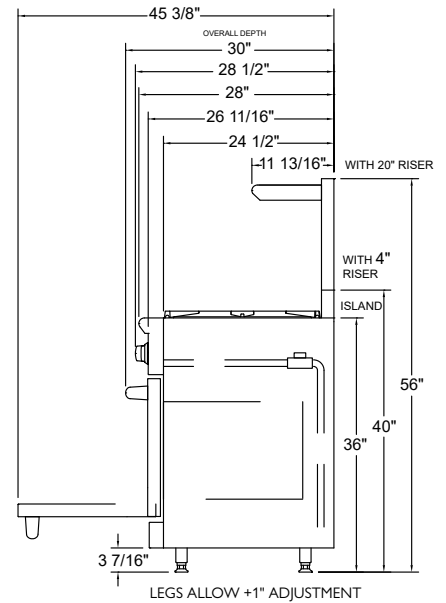
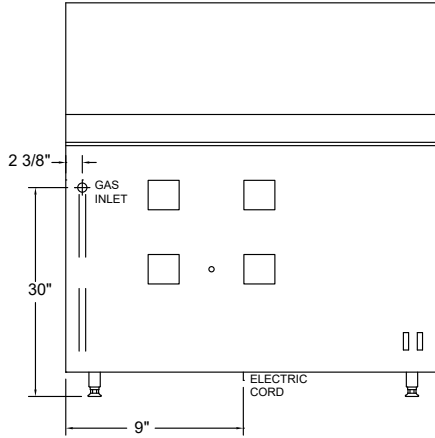
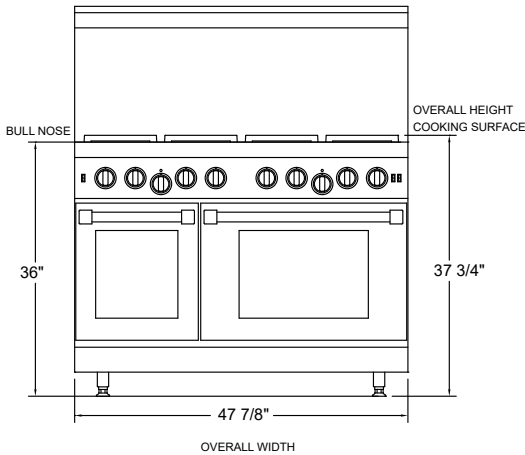

MUST SHIP FROM FACTORY WITH PROPER GAS TYPE
 N=Natural gas L= LP Gas. Must provide N or L after model number for type of gas needed. (Example: ARR488DF-L). Must specify elevation if over 2000 ft. when ordering.

*** ELECTRICAL REQUIREMENTS**
 4-wire, 240VAC, 60 AMP.

A manual gas shut-off valve must be installed external to the appliance, in a location accessible from the front, for the purpose of shutting off the gas supply. This is a vented appliance. To be used in conjunction with a suitable vent hood only.

**The American Range Company continually improves its products and reserves the right to change materials, specifications and dimensions without notice. This unit is manufactured for residential use only.

RECOMMENDED LOCATION OF GAS AND ELECTRICAL SUPPLY
 ISLAND OR PENINSULA INSTALLATIONS 10" MINIMUM CLEARANCE FROM BACK OF RANGE TO COMBUSTIBLE SURFACE

ISLAND TRIM 0 IN. CLEARANCE TO NON COMBUSTIBLE SURFACE
 NO SIDE WALL ABOVE COOKING SURFACE

TECHNICAL SPECIFICATIONS

Overall Oven Capacity	2.7 CU. FT. (18" Oven) – 5.0 CU. FT. (30" Oven)	Electrical Supply	240 VAC 60 AMP 60 Hz Single Phase
Oven Cavity Dimensions	13 3/4" W x 20 1/2" D x 16 1/2" H (18" Oven) (349 x 521 x 419) 25 3/4" W x 20 1/2" D x 16 1/2" H (30" Oven) (654 x 521 x 419)	Gas Supply	7" W.C. Natural, 11" W.C. Propane
Surface Burner Rating	25,000 BTU (lg) – 18,000 BTU (md) – 12,000 BTU (sm)	Broil Element	3,500 WATTS (30" Oven), 2,400 WATTS (18" Oven)
Griddle Burner Rating	20,000 BTU for every 11" section	Bake Element	3,500 WATTS (30" Oven), 2,400 WATTS (18" Oven)
Grill Burner Rating	15,000 BTU for every 11" section	Convection Element	2,500 WATTS (Both Ovens)

Model Number	Description	Overall Dimensions	Total Gas Connection Rating	Shipping Weight	Crated Dimension
ARROB-488DF	8 burners	47 7/8" W x 30" D x 37 3/4" H (1216 x 762 x 959)	166,000 BTU (49 kW)	596 Lbs (270 kg)	49" W x 31" D x 45 1/2" H (1245 x 788 x 1156)
ARROB-486GDFF	6 burners and griddle	47 7/8" W x 30" D x 37 3/4" H (1216 x 762 x 959)	143,000 BTU (42 kW)	609 Lbs (277 kg)	49" W x 31" D x 45 1/2" H (1245 x 788 x 1156)
ARROB-486GRDF	6 burners and grill	47 7/8" W x 30" D x 37 3/4" H (1216 x 762 x 959)	138,000 BTU (40 kW)	594 Lbs (270 kg)	49" W x 31" D x 45 1/2" H (1245 x 788 x 1156)
ARROB-4842GDFF	4 burners and 2 griddles	47 7/8" W x 30" D x 37 3/4" H (1216 x 762 x 959)	120,000 BTU (35 kW)	575 Lbs (261 kg)	49" W x 31" D x 45 1/2" H (1245 x 788 x 1156)
ARROB-4842GRDF	4 burners and 2 grills	47 7/8" W x 30" D x 37 3/4" H (1216 x 762 x 959)	110,000 BTU (32 kW)	603 Lbs (274 kg)	49" W x 31" D x 45 1/2" H (1245 x 788 x 1156)
ARROB-484GDGRDF	4 burners 1 grill 1 griddle	47 7/8" W x 30" D x 37 3/4" H (1216 x 762 x 959)	115,000 BTU (34 kW)	612 Lbs (278 kg)	49" W x 31" D x 45 1/2" H (1245 x 788 x 1156)

ACCESSORIES

1" Island Back (standard)	ARR-48SIB	12" Griddle Cover	ARR-GDCOV12-S	Wok Adapter	ARR-WOK
1" Island Back (welded)	ARR-48IB	12" Grill Cover	ARR-GRCOV12	Extra Oven Rack – 18" Oven	R31035
4" Stub Back	ARR-484SB	12" Griddle Plate	ARR-PGP12	Extra Oven Rack – 30" Oven	R31037
20" High Back w/ Shelf	ARR-4821HBS	24" Griddle Plate	ARR-PGP24	Easy Glide Rack 18"	R31032
S/S Leg Caps (3)	ARR-3LC	24" Griddle Cover	ARR-GDCOV24-S	Easy Glide Rack 30"	R31033
12" Cutting Board	ARR-CUTB-12	24" Grill Cover	ARR-GRCOV24	Porcelainized Broiler Pan	R31005
S/S Curb Base	ARR48CB				

OPTIONS (FACTORY INSTALLED)

11" Chrome Flat Griddle Plate	MC11-FS
11" Chrome Grooved Griddle Plate	MC11-GG
22" Chrome Flat Finish Griddle Plate	MC22FS
22" Cr L. Matte and R. Grooved GR Plate	MC22HG
22" Chrome Flat Finish Griddle Plate	MC22FS
22" Griddle Plate w/ Flavor Separator	MC22-SP

NMFCCODE: 25970-2 Class: 85

© Copyright 2022 American Range
 All Rights Reserved
 R70438 RevB 08312022



QUALITY PROFESSIONAL COOKING EQUIPMENT

4580 N Walnut Rd
 N. Las Vegas, NV 89081
 13592 Desmond St
 Pacoima, CA 91331
 (888) 753-9898

www.AmericanRangehome.com